

# CONTA-ELECTRONICS

## WEBEASY I/O MODULES



## Webeasy I/O Modules

*Compact – Intelligent – Quick – Secure*

Modern buildings are becoming more and more automated. Optimization of the interior climate and the light controls are important functions of a building management system. Factors such as heat, cooling, air humidity and lux levels must all be synchronized. The well-being of inhabitants must also be harmonized with environmental factors, cost effectiveness and energy consumption. In addition the system should be up and running without malfunctions around the clock.

A central controller (a DDC system or PLC controller) is at the heart of every building system. It centralizes the flow of data and information and controls the configuration of parameters. Such a system uses I/O components for connecting up the required sensors and actuators for the control functions.

**CONTA-CLIP's** Webeasy product line provides a variety of modules that meet these requirements for setting up a professional building automation system.



## An open bus system

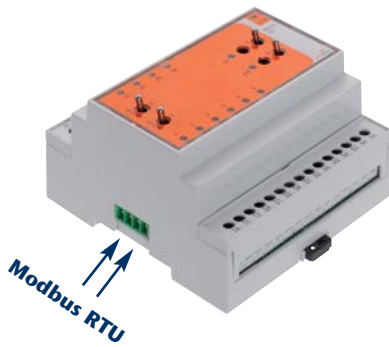

The **CONTA-CLIP Webeasy** modules are bus-based components that can be installed either centralized in the electrical cabinet or decentralized in the field.

The data transmission takes place over a serial interface using the Modbus RTU protocol. This allows it to easily be integrated within various controller designs.

The Modbus RTU protocol is normally supported by all providers of controller systems.

It is quite easy to use: after the corresponding **Webeasy** modules are addressed, an entry is made in the designated register in the software.

## Permanent control of the outputs



Building parameters must be under control 24 hours a day. It must be possible to control them even when a software malfunction occurs at the controller level or when the system is being serviced.

The **Webeasy** modules enable you to control the system manually since practically all output modules are fitted with a Manual/Off/Automatic switch. This intervention switch can be used to disconnect field devices from the automated system in order to allow the facility to be run in an emergency situation.

So it would still be possible during a malfunction to separately operate the heating and ventilation systems.



### Automated control without being on-site

There may not always be a service technician nearby when the time comes to use this intervention switch. The **Webeasy** modules feature an integrated processor which can run an emergency routine. This programmed routine describes what actions to take in the event of a malfunction. For example, you can specify that all outputs should be switched to ON in the event of a malfunction.

## Quick and easy installation of the power supply and bus cable

The **Webeasy** (WE) modules have been designed for both centralized (in the electrical cabinet) or decentralized (in the field) signal transmission. They are quite simple to install.

At the local I/O level, the modules can simply be clicked together using the integrated WE plug-in connector to form the electrical connection between the required modules. The power supply and the Modbus serial interface are automatically fed in over the WE connector. Thus your installation becomes more efficient since you no longer need any additional cabling!

A standard twisted-pair cable can be used for the bus connection in a decentralized setup.



## Simple and convenient to configure



An address from 0 to 99 can be selected for the bus assignment by using the two rotary switches.

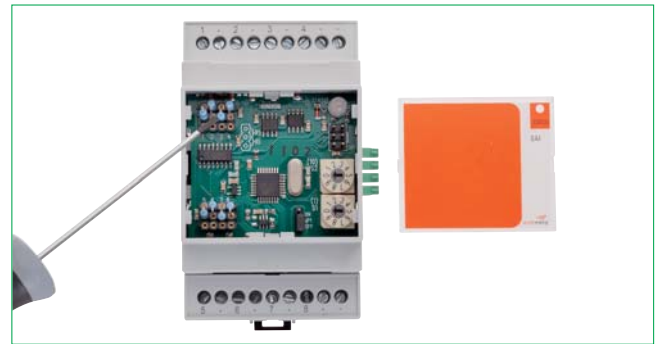

All analog inputs are multi-functional; this means that a different signal (0 – 10 V, 0(4) – 20 mA, RTD) can be selected for each channel. The input type and the input value are set using standard resistors.

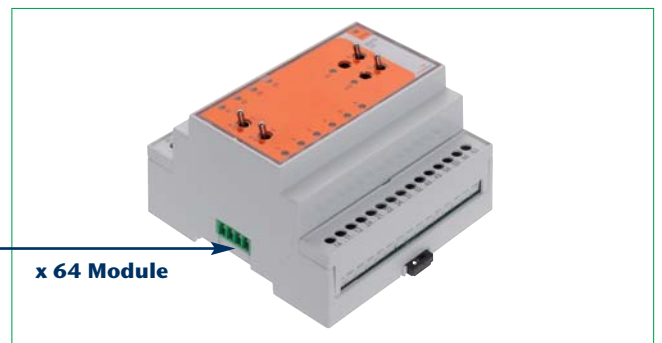
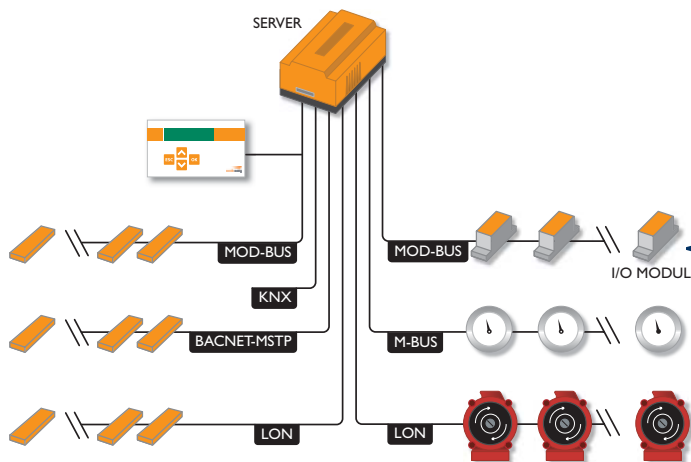

Up to 64 **Webeasy** modules can be connected on one bus. The cable length can be as long as 500 meters.

### A summary of the features:

- Quick, compact, intelligent and secure
- Open system / Modbus RTU
- Can be controlled manually by using the intervention switch
- Compulsory control in event of communication interruption
- Quick and easy to install
- Simple and convenient to configure
- Can be extended up to 64 modules

## Webeasy I/O Modules

### WE-8AI Analog Input Module

- 8 Multi-funktion analog inputs:  
0...10 V, 0(4)..20 mA, RTD (PT1000 / NI1000)
- Easy addressing through rotary switches
- TS 35 or Direct mounting
- LED status indication

### WE-8AI

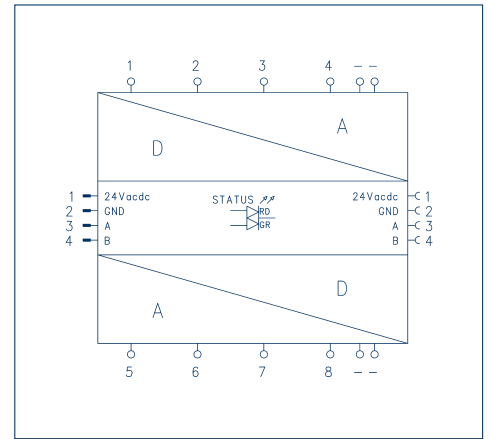

#### Type

#### Cat. no.

Size (L x W x H) with TS 35 x 7.5 / Direct

#### Weight

#### Input data

8 Multi-function analog inputs

Resolution / accuracy (V / I / RTD)

Input resistance (0..10 V)

Input resistance (0(4)..20 mA)

Reference resistance (RTD)

### WE-8AI

#### 15477.2

53 x 95 x 60 / 58 mm

117 g

#### Qty

1

General Information	
Power supply	20...28 V AC/ DC
Power consumption	125 mA AC / 50 mA DC
Module LED status indication	run - no communication - Error
Installation guidelines	see Manual Webeasy I/O modules

0..10 V / 0(4)..20 mA / RTD (default: 8x RTD)
10 mV / $\pm(10 \text{ mV} + 0,3\%*)$ ; 20 $\mu\text{A}$ / $\pm(20 \mu\text{A} + 0,4\%*)$ ; NI1000: 0,1 °C / $\pm 0,4^\circ\text{C}$ ob PT1000: 0,1 °C / $\pm 0,6^\circ\text{C}$
resistor type: fixed, 200 kOhm
resistor type: plug-in (Ri), 250 Ohm $\pm 0,1\%$ . (resistor not included)
resistor type: plug-in (Rt), sensor dependant $\pm 0,1\%$ (default: 5 k11 for Ni/Pt1000 RTD -40..+120°C)

### WE-10DI Digital Input Module

- 10 Digital inputs 24 V AC / DC
- LED indication per input
- LED color selectable by software red or green
- Easy addressing through rotary switches
- TS 35 or Direct mounting
- LED status indication

### WE-10DI

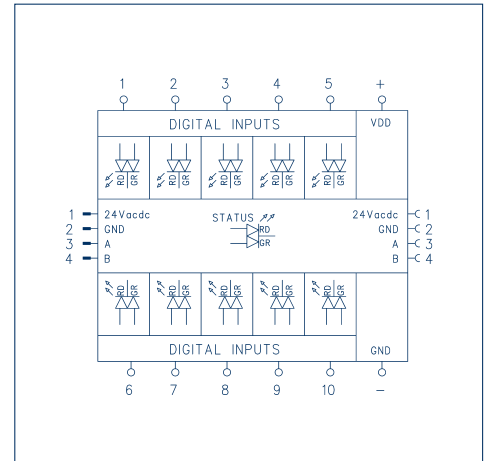

#### Type

#### Cat. no.

Size (L x W x H) with TS 35 x 7.5 / Direct

#### Weight

#### Input data

10 Digital inputs

Logic '0' AC / DC

Max frequency AC / DC

Minimum pulse length AC / DC

Input resistance

VDD (+) output

LED status indication per input

### WE-10DI

#### 15473.2

53 x 95 x 60 / 58 mm

121 g

#### Qty

1

General Information	
Power supply	20...28 V AC/ DC
Power consumption	75 mA AC / 30 mA DC
Module LED status indication	run - no communication - Error
Installation guidelines	see Manual Webeasy I/O module

24 V AC (12...28V) / 24 V DC (10...30V)
<2 V / <3 V
10 Hz / 20 Hz
50 ms / 15 ms
60 kOhm
to be used only for the inputs of this module
depends on selected input type; color: green/red/off

\* of measured value

### WE-4DO Digital Output Module

- 4 Digital relay outputs, one changeover contact per output
- Max. rated current 16 A per relay
- Yellow LED indication per channel
- Failsafe: outputs are set to a predefined state when communication is lost
- Easy addressing through rotary switches
- TS 35 or Direct mounting
- LED status indication

### WE-4DO

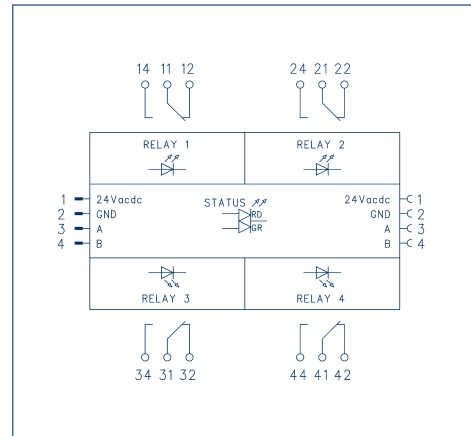

<b>Type</b>	
<b>Cat. no.</b>	
Size (L x W x H) with TS 35 x 7.5 / Direct	
Weight	
<b>Output data</b>	
4 Relay outputs	
Rated / inrush current (ohmic load)	
Max. power rating / total module current	
Llife span at 23°C and ohmic load	
Max. switching frequency	
Contact material / Rated surge voltage	
LED status indication per output	
<b>General Information</b>	
Power supply	
Power consumption	
Module LED status indication	
Installation guidelines	

<b>WE-4DO</b>	<b>Qty</b>
<b>15474.2</b>	<b>1</b>
53 x 95 x 60 / 58 mm	
154 g	
4 x CO contact / 250 V~	
16 A / 80 A (20 ms)	
4000 VA / 32 A	
Electrical: at rated / 4 A Load: 1 x 10 <sup>5</sup> / 7 x 10 <sup>5</sup> cycles. Mechanical: > 30 x 10 <sup>6</sup> cycles	
6 min <sup>-1</sup> at rated current, 1200 min <sup>-1</sup> at no load	
AgSnO <sub>2</sub> / 4 kV	
yellow	
20...28 V AC/ DC	
250 mA AC / 100 mA DC	
run - no communication - Error	
see Manual Webeasy I/O modules	

### WE-4AOH-3DO Analog and Digital Output Module

- 4 analog outputs, 0...10 V
- Feedback measurement of the analog outputs
- Override switch (auto-manual) per analog output
- Switch position signalling circuit
- Yellow LED indication per analog output
- In manual position the analog output can be adjusted with a potentiometer
- 3 Relay outputs
- One changeover contact 250 V / 8 A per output
- Failsafe: outputs are set to a predefined state when communication is lost
- Easy addressing through rotary switches
- TS 35 or Direct mounting
- LED status indication

### WE-4AOH-3DO

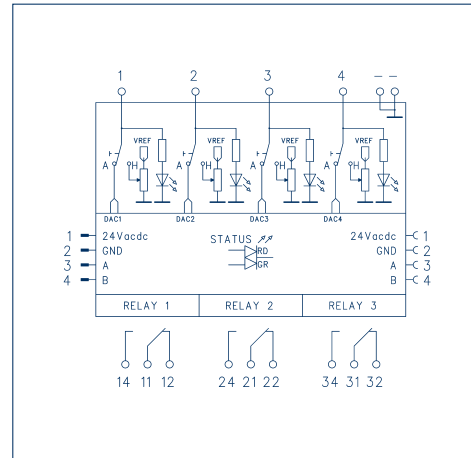

<b>Type</b>	
<b>Cat. no.</b>	
Size (L x W x H) with TS 35 x 7.5 / Direct	
Weight	
<b>Output data</b>	
4 analog outputs	
Load resistance / current per channel	
Resolution / conversion error	
Temperature coefficient	
LED status indication per output	
3 Relay outputs	
Rated / inrush current (ohmic load)	
Max. power rating / total module current	
Llife span at 23°C and ohmic load	
Max. switching frequency	
Contact material / Rated surge voltage	
<b>General Information</b>	
Power supply	
Power consumption	
Module LED status indication	
Installation guidelines	

<b>WE-4AOH-3DO</b>	<b>Qty</b>
<b>15478.2</b>	<b>1</b>
53 x 95 x 60 / 58 mm	
157 g	
0...10 V DC	
> 1 kOhm / < 10 mA	
10 mV / ± (30 mV + 0,5% of measured value)	
typ. 0,02% / °C	
yellow	
3 x CO contact / 250 V~	
8 A / 12 A	
2000 VA / 24 A	
Electrical: at rated / 2 A load: 1 x 10 <sup>5</sup> / 4 x 10 <sup>5</sup> cycles. Mechanical: 30 x 10 <sup>6</sup> cycles	
6 min <sup>-1</sup> at rated current, 1200 min <sup>-1</sup> at no load	
AgNi 0,15 / 4 kV	
20...28 V AC/ DC	
240 mA AC / 95 mA DC	
run - no communication - Error	
see Manual Webeasy I/O modules	

## Webeasy I/O Modules

### WE-6DOH-12DI Digital I/O Module

- 12 Digital inputs 24 V AC / DC
- LED Indication per input, 6x red und 6x green
- 6 Relay outputs: 3 changeover contacts 250 V / 8 A, 3 normally open contacts 250 V / 8 A
- Override switch (auto-off-manual) per relay output
- Switch position signalling circuit
- Failsafe: outputs are set to a predefined state when communication is lost
- Easy addressing through rotary switches
- TS 35 or Direct mounting
- LED status indication

### WE-6DOH-12DI

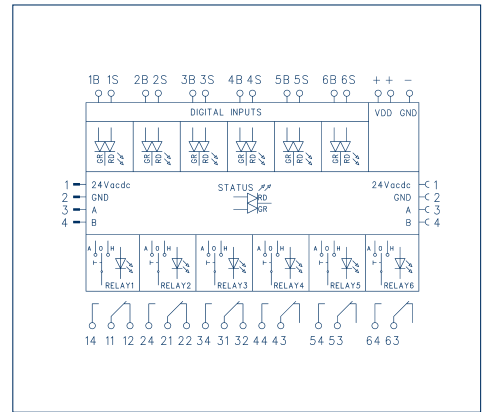

#### Type Cat. no.

Size (L x W x H) with TS 35 x 7.5 / Direct  
Weight

#### Input data

12 Digital inputs  
Logic '0'

Input resistance

LED status indication

#### Output data

6 Relay outputs

Rated / inrush current (ohmic load)

Max. power rating / total module current

Life span at 23°C and ohmic load

Max. switching frequency

Contact material / Rated surge voltage

#### General Information

Power consumption

### WE-6DOH-12DI 15475.2

88 x 95 x 60 / 88 mm  
231 g

24 V AC (12...28 V) / 24 V DC (10...30 V)  
<2 V

≥ 6 kOhm

6 x red (input S) - 6 x green (input B)

3 x 1 CO contact - 3 x 1 NO contact / 250 V~

8 A / 12 A

2000 VA / 32 A

Electrical: at rated / 2A Load: 1 x 10<sup>5</sup> / 4 x 10<sup>5</sup> cycles. Mechanical: 30 x 10<sup>6</sup> cycles

6 min<sup>-1</sup> at rated current, 1200 min<sup>-1</sup> at no load

AgNi 0,15 / 4 kV

275 mA AC / 110 mA DC

Qty  
1

### WE-MULTI-I/O Analog and Digital I/O Module

- 4 Digital inputs 24 V AC / DC
- 6 Multi function inputs Analog / Digital: 0...10 V, 0(4)..20 mA, RTD (PT1000/NI1000)/24 V DC
- 2 Analog outputs, 0...10 V (4..20 mA output on request)
- Override switch (auto-off-manual) per analog output
- In manual position the analog output can be adjusted with a potentiometer
- 6 Relay outputs: 3 changeover contacts 250 V / 8 A, 3 normally open contacts 250 V / 8 A
- Override switch (auto-off-manual) for two relay outputs
- LED status indication on all I/O's (except analog inputs)
- Easy addressing through rotary switches
- TS 35 or Direct mounting
- LED status indication

### WE-MULTI-I/O

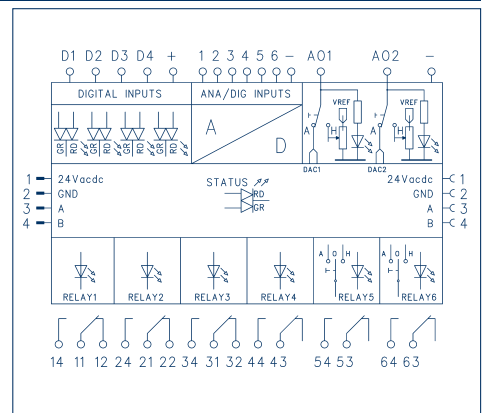

#### Type Cat. no.

Size (L x W x H) with TS 35 x 7.5 / Direct  
Weight

#### Input data

4 Digital inputs

Logic '0' AC / DC

Input resistance

LED status indication per input

6 Multi-function inputs analog / digital

Resolution / accuracy (V / I / RTD)

Input resistance (0..10 V)

Input resistance ( 0(4)..20 mA)

Reference resistance (RTD)

input current digital input (10-30 V DC)

#### Output data

2 Analog outputs

Load resistance / current per channel

Resolution / conversion error

6 Relay outputs

Rated / inrush current (ohmic load)

#### General Information

Power consumption

### WE-MULTI-I/O 15565.2

88 x 95 x 60 / 88 mm  
236 g

24 V AC (12...28 V) / 24 V DC (10...30 V)

<2 V / <3 V

60 kOhm

depends on selected input type: red / green / off

0..10 V / 0(4)..20 mA / RTD / 24 V DC (default 6 x RTD)

10 mV / ±(10 mV+0,3%\*); 20 µA / ±(20 µA+0,4%\*); NI1000: 0,1°C / ±0,4°C or PT1000: 0,1°C / ±0,6°C

resistor type: fixed, 200 kOhm

resistor type: Plug-in (Ri), 250 Ohm ± 0,1%. (resistor not included)

resistor type: plug-in (Rt), sensor dependant ± 0,1% (default: 5k11 for Ni/Pt1000 RTD -40..+120°C)

min. @10 V: 46 µA / Typ. @24 V: 2,6 mA / max. @30 V: 3,9 mA

0...10 V DC

> 1 kOhm / < 10 mA

10 mV / ± (30 mV + 0,5% \*)

3 x 1 CO contact - 3 x 1 NO contact / 250 V~

8 A / 12 A

310 mA AC / 125 mA DC

Qty  
1

\* of measured value

## WE-CON / WE-CON-R Connection Module

- Easy Power and Bus connection via standard screw terminals
- WE-CON: Protection against overvoltage and overcurrent on Power and Bus terminals
- WE-CON: Integrated termination resistor, activate via dipswitch
- TS 35 or Direct mounting

## WE-CON

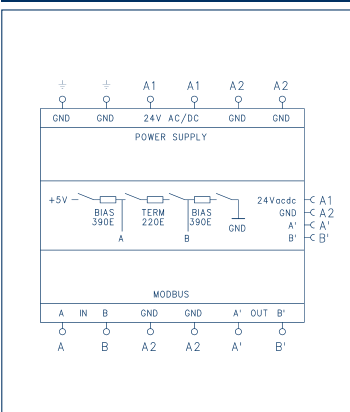

## WE-CON-R

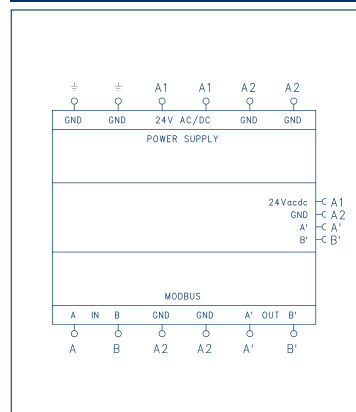

Type	WE-CON	Qty	WE-CON-R	Qty
<b>Cat. no.</b>	<b>15745.2</b>	<b>1</b>	<b>15984.2</b>	<b>1</b>
Size (L x W x H) with TS 35 x 7.5	36 x 95 x 60 / 58 mm		36 x 95 x 60 / 58 mm	
Weight	71 g		61 g	
<b>Power Supply</b>				
Power supply	20...28 V AC/ DC		20...28 V AC/ DC	
Power consumption	30 mA AC / 10 mA DC		-	
Max output current	5 A		5 A	
External fuse (recommended)	6,3 A T		6,3 A T	
Protection	Varistor (S14K30)		-	
<b>Bus Daten</b>				
Bus line termination	integrated termination resistors TERM: 220 Ohm and BIAS (pull-up/down): 390 Ohm activate via dipswitch (default: TERM: off / BIAS: off)		-	

## General data for all modules

### Webeasy Bus data

Bus protocol	Modbus-RTU
Bus interface	RS485, half duplex, not isolated
Bus topology / length max.	multidrop / 500 m
Bus speed	19 k2 bps
Bus nodes max.	64
Bus line termination	integrated termination resistor, activate via jumper (default: off)
Bus protection	built-in transient protection
Bus connector local	pluggable integrated connector male / female
Bus cabling	twisted pair shielded (see Manual Webeasy I/O modules)

### General Information

Power supply	20...28 V AC/ DC
Module LED status indication (Bi-color)	run - no communication - Error
Operating temperature	0°C...+50°C
Storage temperature	-20°C...+70°C
EMC specifications	Low Voltage Directive (LVD) 2006/95/EC, according requirements of EN 50178
Electromagnetic properties	EMC Directive 2004/108/EC, according requirements of EN 55011 and EN 61326-1
Connection type	screw
Connection cross-section	0,2 - 2,5 mm <sup>2</sup>
Stripping length	6 mm
Mounting	DIN-rail TS35 / Direktmontage
Insulating material housing / terminals	noryl / polyamid 6.6
Flammability class UL94	V0
Protection degree	IP 20
Installation guidelines	for mounting-, wiring- and installation instructions, see Manual

## Accessories

		Qty
WE-Bus connector female (Input)	WE-BUSCONNECTOR FEMALE 4P	
<b>Best.-Nr.</b>	<b>15566.2</b>	50
WE-Bus connector male (output)	WE-BUSCONNECTOR MALE 4P	
<b>Best.-Nr.</b>	<b>15567.2</b>	50

**CONTA-CONNECT**  
[Connection Systems]



**CONTA-ELECTRONICS**  
[Elektronics]

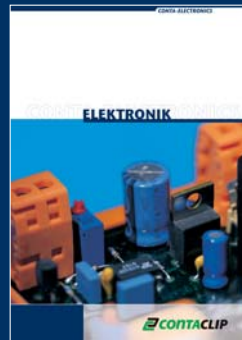

**CONTA-CON**  
[PCB Connectors]

